



CULLET CONVEYOR INTERMEDIATE ASSEMBLY

12" BELT WIDTH

AVAILABLE IN

SLIDER BED OR ROLLER CONVEYOR

WITH

STANDARD OR HIGH SIDES

PART NO: 00B30310
 CULLET CONVEYOR SLIDER BED ASSEMBLY
 STANDARD SIDES
 12" BELT WIDTH

ITEM	PART NO.	DESCRIPTION	QTY.
1	01B30002	SLIDER STYLE SIDE FRAME WELDMENT	2
2	01B30103	CHANNEL CROSS TIE WELDMENT	3
3	01B30600	SUPPORT WELDMENT 10"-16" BELT HEIGHT	2
4	02B30300	RETURN ROLLER MOUNTING BRACKET	4
5	02B30673	10"-16" SUPPORT BRACE	2
6	02B30305	KEEPER PLATE RETURN ROLL	4
7	02B30833	RETURN ROLLER SLIDER/ROLLER CONVEYOR	2
8	01B05500	STANDARD FOOT PAD WELDMENT	2

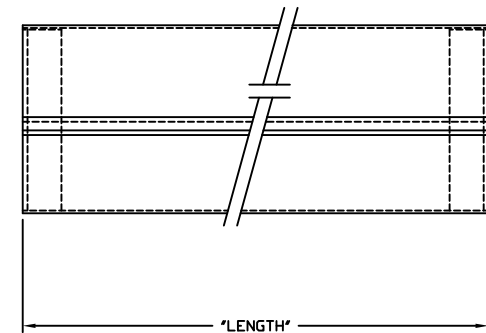
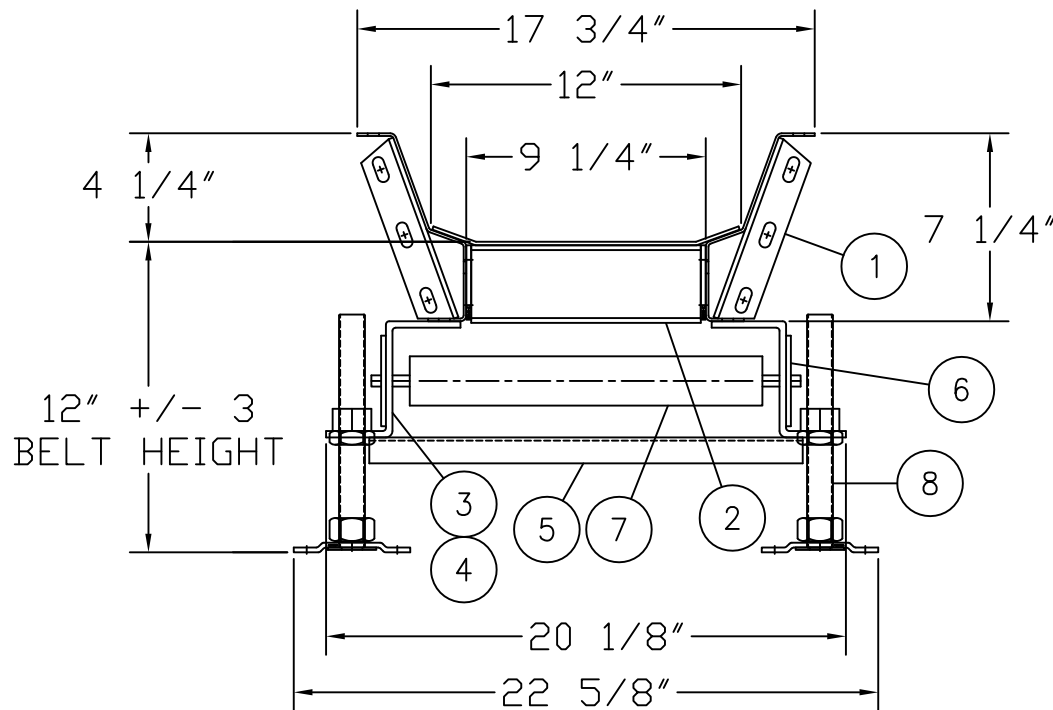

NOTES:

MINIMUM BELT HEIGHT IS 8"
 ONE SUPPORT PROVIDED EACH SECTION
 TWO RETURN ROLLERS PER 10' SECTION



C:/ACAD/PROD/30/00B30310

7620 EVERGREEN ST.
 LIMA, NY 14485
 (v) 585.624.7850 (f) 585.624.8015
 1.888.NECONVEY (1.888.632.6683)
 (e) conveyor@neind.com

PART NO: 00B30311
 CULLET CONVEYOR ROLLER BED ASSEMBLY
 STANDARD SIDES
 12" BELT WIDTH

ITEM	PART NO.	DESCRIPTION	QTY.
1	01B30001	ROLLER STYLE SIDE FRAME WELDMENT	2
2	01B30053	ANGLE CROSS TIE WELDMENT	3
3	01B30600	SUPPORT WELDMENT 10"-16" BELT HEIGHT	2
4	02B30300	RETURN ROLLER MOUNTING BRACKET	4
5	02B30673	10"-16" SUPPORT BRACE	2
6	02B30305	KEEPER PLATE RETURN ROLL	4
7	02B30833	RETURN ROLLER SLIDER/ROLLER CONVEYOR	2
8	01B05500	STANDARD FOOT PAD WELDMENT	2
9	05B30803	CARRY ROLLER SLIDER/ROLLER CONVEYOR	5

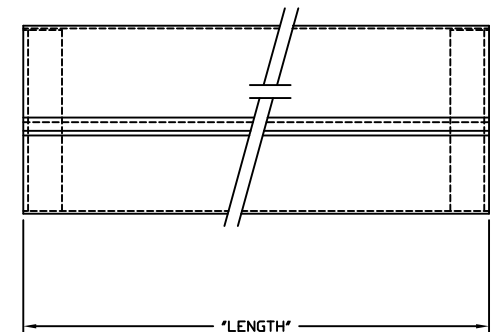
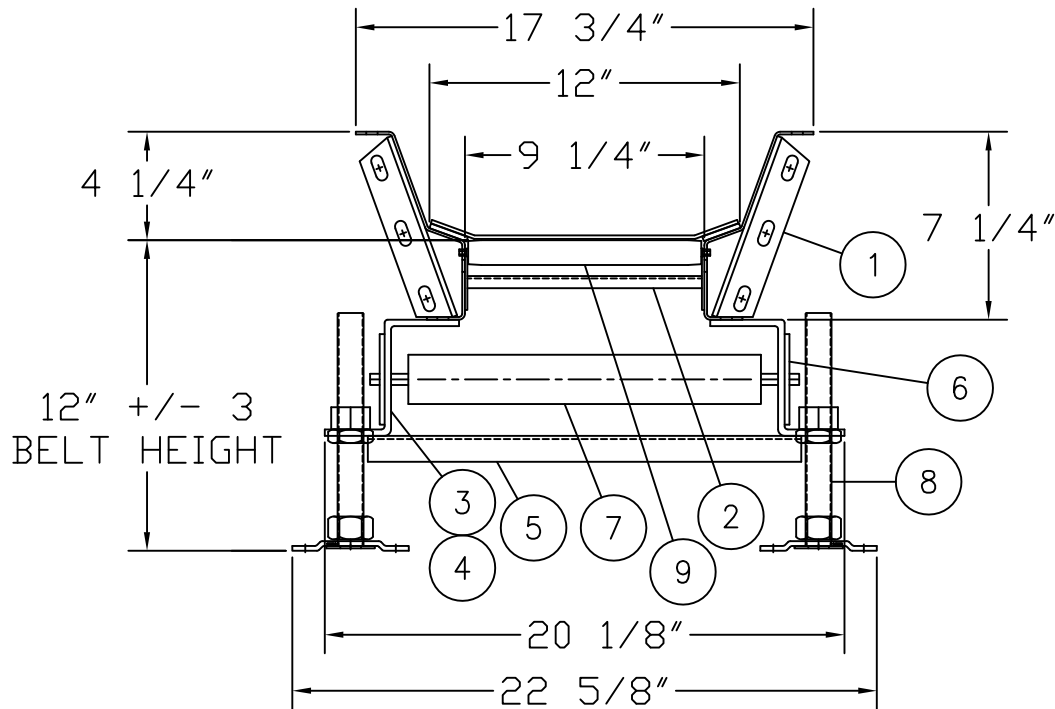

NOTES:

MINIMUM BELT HEIGHT IS 8"
 ONE SUPPORT PROVIDED EACH SECTION
 TWO RETURN ROLLERS PER 10' SECTION



7620 EVERGREEN ST.
 LIMA, NY 14485
 (v) 585.624.7850 (f) 585.624.8015
 1.888.NECONVEY (1.888.632.6683)
 (e) conveyor@neind.com

PART NO: 00B30312
 CULLET CONVEYOR SLIDER BED ASSEMBLY
 HIGH SIDES
 12" BELT WIDTH

ITEM	PART NO.	DESCRIPTION	QTY.
1	01B30004	SLIDER STYLE SIDE FRAME WELDMENT	2
2	01B30103	CHANNEL CROSS TIE WELDMENT	3
3	01B30600	SUPPORT WELDMENT 10"-16" BELT HEIGHT	2
4	02B30300	RETURN ROLLER MOUNTING BRACKET	4
5	02B30673	10"-16" SUPPORT BRACE	2
6	02B30305	KEEPER PLATE RETURN ROLL	4
7	02B30833	RETURN ROLLER SLIDER/ROLLER CONVEYOR	2
8	01B05500	STANDARD FOOT PAD WELDMENT	2

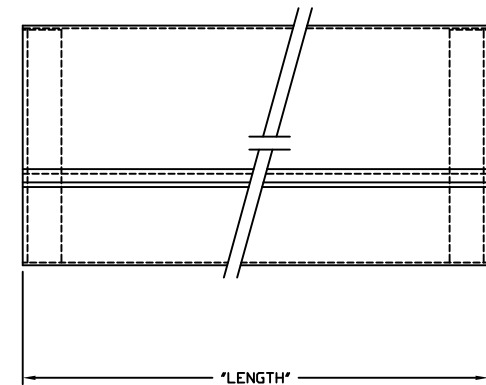
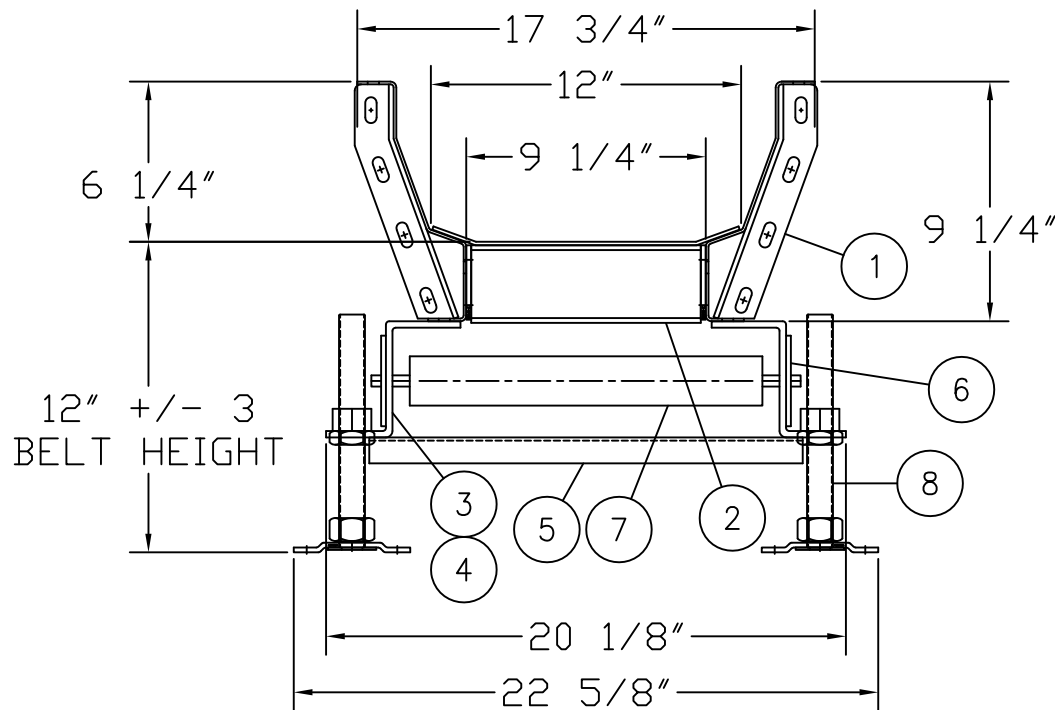

NOTES:
 MINIMUM BELT HEIGHT IS 8"
 ONE SUPPORT PROVIDED EACH SECTION
 TWO RETURN ROLLERS PER 10' SECTION



7620 EVERGREEN ST.
 LIMA, NY 14485
 (v) 585.624.7850 (f) 585.624.8015
 1.888.NECONVEY (1.888.632.6683)
 (e) conveyor@neind.com

PART NO: 00B30313
 CULLET CONVEYOR ROLLER BED ASSEMBLY
 HIGH SIDES
 12" BELT WIDTH

ITEM	PART NO.	DESCRIPTION	QTY.
1	01B30006	ROLLER STYLE SIDE FRAME WELDMENT	2
2	01B30053	ANGLE CROSS TIE WELDMENT	3
3	01B30600	SUPPORT WELDMENT 10"-16" BELT HEIGHT	2
4	02B30300	RETURN ROLLER MOUNTING BRACKET	4
5	02B30673	10"-16" SUPPORT BRACE	2
6	02B30305	KEEPER PLATE RETURN ROLL	4
7	02B30833	RETURN ROLLER SLIDER/ROLLER CONVEYOR	2
8	01B05500	STANDARD FOOT PAD WELDMENT	2
9	05B30803	CARRY ROLLER SLIDER/ROLLER CONVEYOR	5

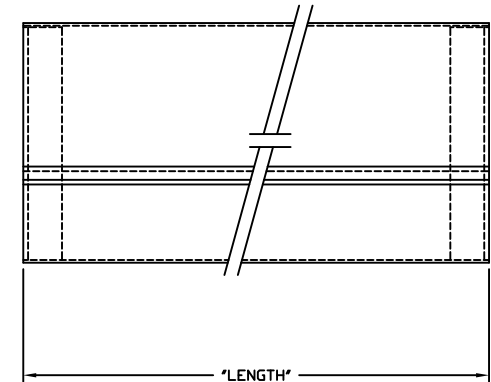
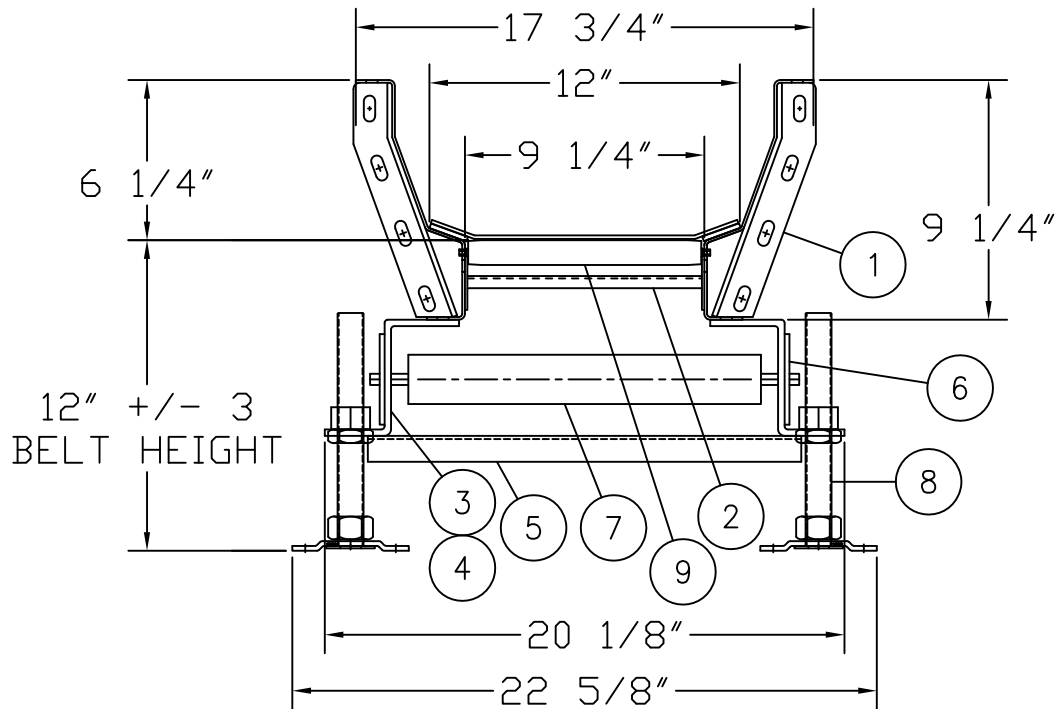

NOTES:

MINIMUM BELT HEIGHT IS 8"
 ONE SUPPORT PROVIDED EACH SECTION
 TWO RETURN ROLLERS PER 10' SECTION



7620 EVERGREEN ST.
 LIMA, NY 14485
 (v) 585.624.7850 (f) 585.624.8015
 1.888.NECONVEY (1.888.632.6683)
 (e) conveyor@neind.com



CULLET CONVEYOR INTERMEDIATE ASSEMBLY

18" BELT WIDTH

AVAILABLE IN

SLIDER BED OR ROLLER CONVEYOR

WITH

STANDARD OR HIGH SIDES

PART NO: 00B30315
 CULLET CONVEYOR SLIDER BED ASSEMBLY
 STANDARD SIDES
 18" BELT WIDTH

ITEM	PART NO.		
1	01B30002	SLIDER STYLE SIDE FRAME WELDMENT	2
2	01B30109	CHANNEL CROSS TIE WELDMENT	3
3	01B30600	SUPPORT WELDMENT 10"-16" BELT HEIGHT	2
4	02B30300	RETURN ROLLER MOUNTING BRACKET	4
5	02B30679	10"-16" SUPPORT BRACE	2
6	02B30305	KEEPER PLATE RETURN ROLL	4
7	02B30839	RETURN ROLLER SLIDER/ROLLER CONVEYOR	2
8	01B05500	STANDARD FOOT PAD WELDMENT	2

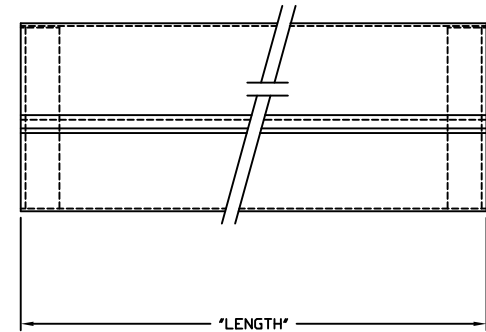
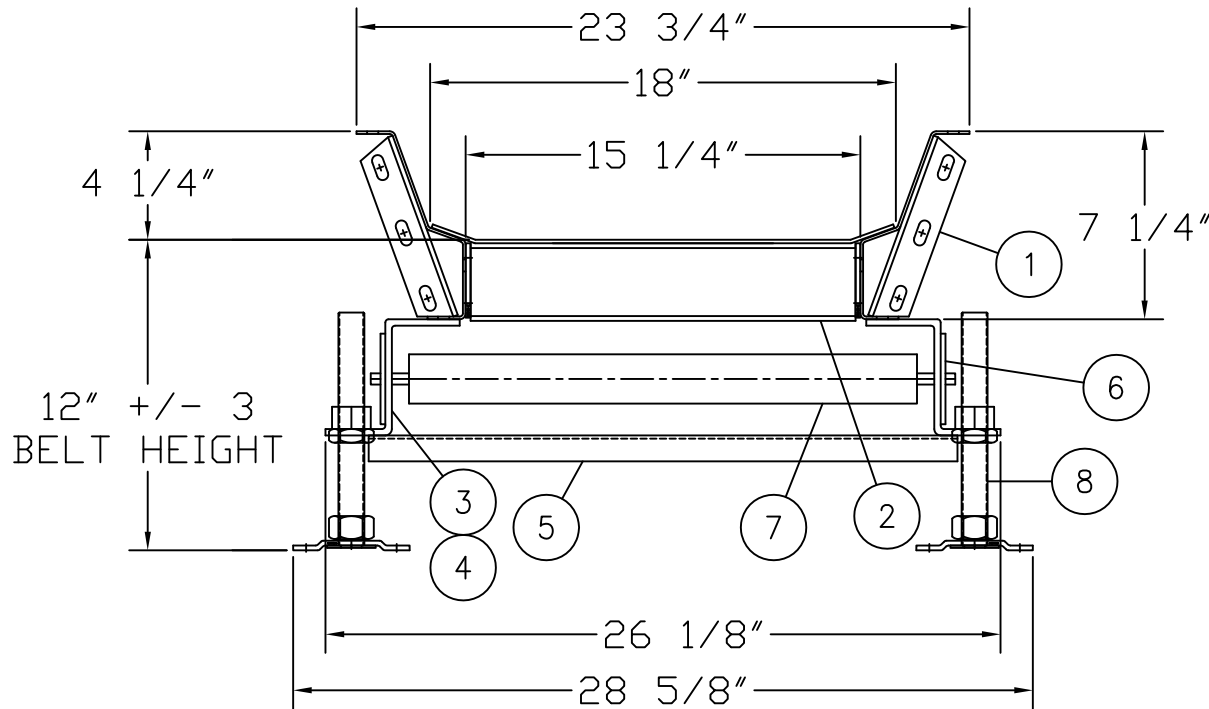

NOTES:

MINIMUM BELT HEIGHT IS 8"
 ONE SUPPORT PROVIDED EACH SECTION
 TWO RETURN ROLLERS PER 10' SECTION



7620 EVERGREEN ST.
 LIMA, NY 14485
 (v) 585.624.7850 (f) 585.624.8015
 1.888.NECONVEY (1.888.632.6683)
 (e) conveyor@neind.com

PART NO: 00B30316
 CULLET CONVEYOR ROLLER BED ASSEMBLY
 STANDARD SIDES
 18" BELT WIDTH

ITEM	PART NO.		
1	01B30001	ROLLER STYLE SIDE FRAME WELDMENT	2
2	01B30059	ANGLE CROSS TIE WELDMENT	3
3	01B30600	SUPPORT WELDMENT 10"-16" BELT HEIGHT	2
4	02B30300	RETURN ROLLER MOUNTING BRACKET	4
5	02B30679	10"-16" SUPPORT BRACE	2
6	02B30305	KEEPER PLATE RETURN ROLL	4
7	02B30839	RETURN ROLLER SLIDER/ROLLER CONVEYOR	2
8	01B05500	STANDARD FOOT PAD WELDMENT	2
9	05B30809	CARRY ROLLER SLIDER/ROLLER CONVEYOR	5

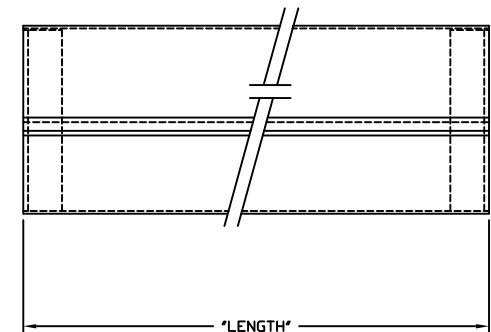
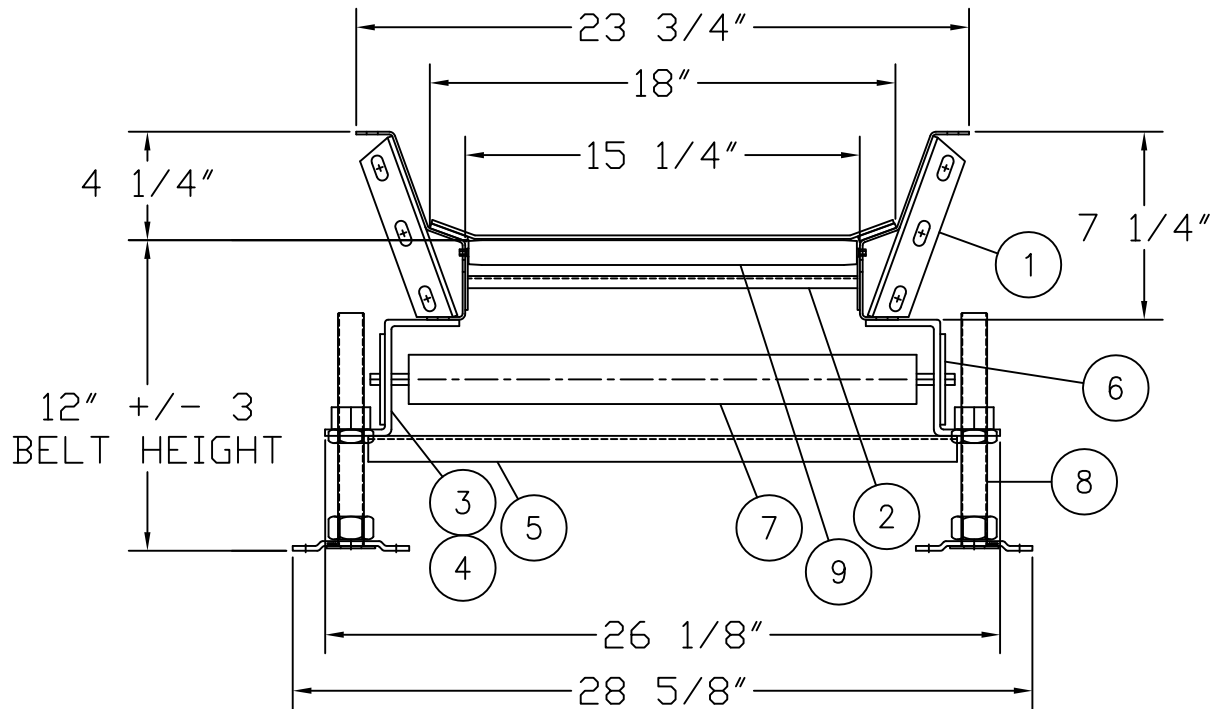

NOTES:

MINIMUM BELT HEIGHT IS 8"
 ONE SUPPORT PROVIDED EACH SECTION
 TWO RETURN ROLLERS PER 10' SECTION



7620 EVERGREEN ST.
 LIMA, NY 14485
 (v) 585.624.7850 (f) 585.624.8015
 1.888.NECONVEY (1.888.632.6683)
 (e) conveyor@neind.com

PART NO: 00B30317
 CULLET CONVEYOR SLIDER BED ASSEMBLY
 HIGH SIDES
 18" BELT WIDTH

ITEM	PART NO.		
1	01B30004	SLIDER STYLE SIDE FRAME WELDMENT	2
2	01B30109	CHANNEL CROSS TIE WELDMENT	3
3	01B30600	SUPPORT WELDMENT 10"-16" BELT HEIGHT	2
4	02B30300	RETURN ROLLER MOUNTING BRACKET	4
5	02B30679	10"-16" SUPPORT BRACE	2
6	02B30305	KEEPER PLATE RETURN ROLL	4
7	02B30839	RETURN ROLLER SLIDER/ROLLER CONVEYOR	2
8	01B05500	STANDARD FOOT PAD WELDMENT	2

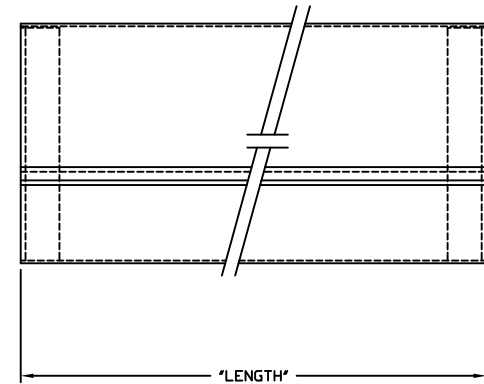
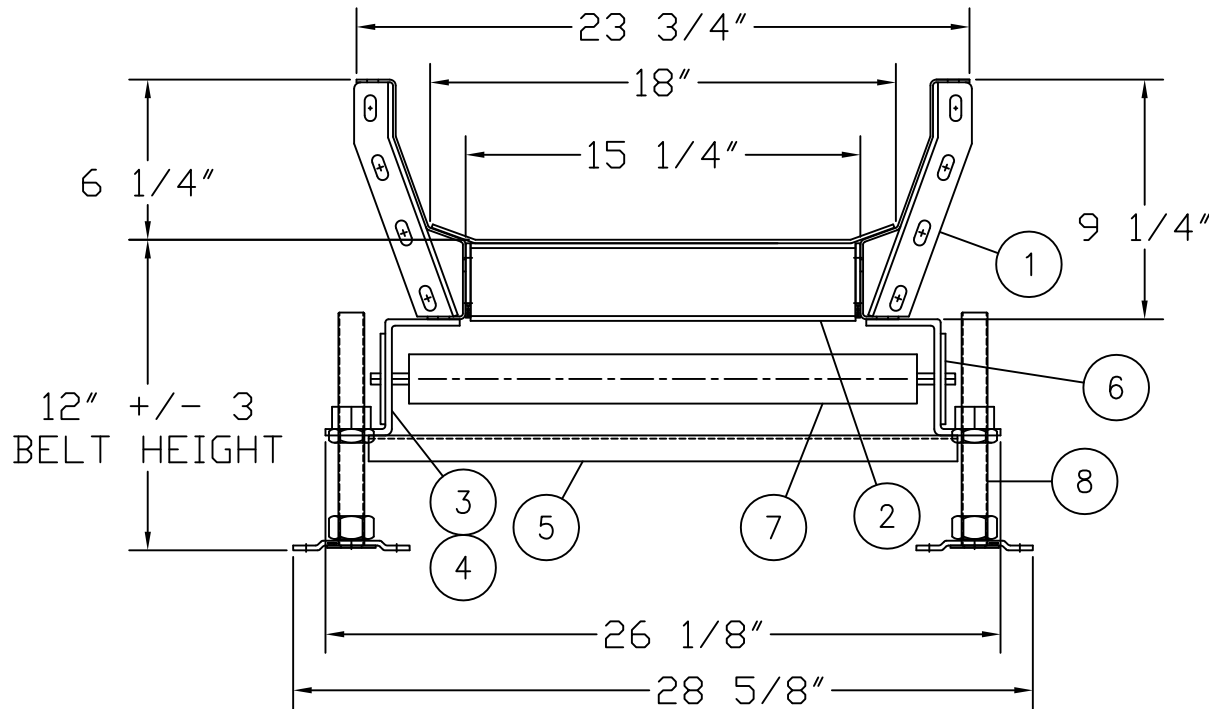

NOTES:

MINIMUM BELT HEIGHT IS 8"
 ONE SUPPORT PROVIDED EACH SECTION
 TWO RETURN ROLLERS PER 10' SECTION



7620 EVERGREEN ST.
 LIMA, NY 14485
 (v) 585.624.7850 (f) 585.624.8015
 1.888.NECONVEY (1.888.632.6683)
 (e) conveyor@neind.com

PART NO: 00B30318
 CULLET CONVEYOR ROLLER BED ASSEMBLY
 HIGH SIDES
 18" BELT WIDTH

ITEM	PART NO.		
1	01B30006	ROLLER STYLE SIDE FRAME WELDMENT	2
2	01B30059	ANGLE CROSS TIE WELDMENT	3
3	01B30600	SUPPORT WELDMENT 10"-16" BELT HEIGHT	2
4	02B30300	RETURN ROLLER MOUNTING BRACKET	4
5	02B30679	10"-16" SUPPORT BRACE	2
6	02B30305	KEEPER PLATE RETURN ROLL	4
7	02B30839	RETURN ROLLER SLIDER/ROLLER CONVEYOR	2
8	01B05500	STANDARD FOOT PAD WELDMENT	2
9	05B30809	CARRY ROLLER SLIDER/ROLLER CONVEYOR	5

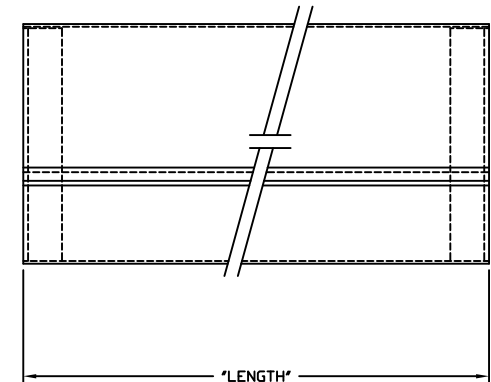
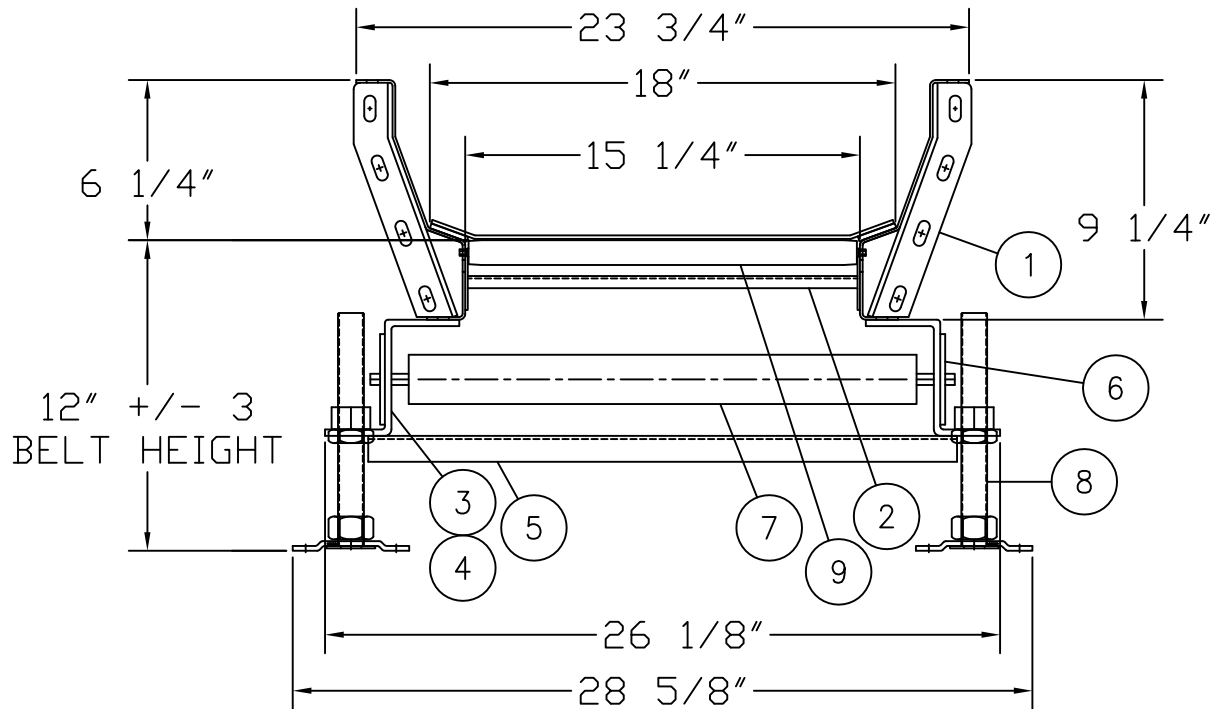

NOTES:

MINIMUM BELT HEIGHT IS 8"
 ONE SUPPORT PROVIDED EACH SECTION
 TWO RETURN ROLLERS PER 10' SECTION



7620 EVERGREEN ST.
 LIMA, NY 14485
 (v) 585.624.7850 (f) 585.624.8015
 1.888.NECONVEY (1.888.632.6683)
 (e) conveyor@neind.com



CULLET CONVEYOR INTERMEDIATE ASSEMBLY

24" BELT WIDTH

AVAILABLE IN

SLIDER BED OR ROLLER CONVEYOR

WITH

STANDARD OR HIGH SIDES

PART NO: 00B30320
 CULLET CONVEYOR SLIDER BED ASSEMBLY
 STANDARD SIDES
 24" BELT WIDTH

ITEM	PART NO.		
1	01B30002	SLIDER STYLE SIDE FRAME WELDMENT	2
2	01B30115	CHANNEL CROSS TIE WELDMENT	3
3	01B30600	SUPPORT WELDMENT 10"-16" BELT HEIGHT	2
4	02B30300	RETURN ROLLER MOUNTING BRACKET	4
5	02B30685	10"-16" SUPPORT BRACE	2
6	02B30305	KEEPER PLATE RETURN ROLL	4
7	02B30845	RETURN ROLLER SLIDER/ROLLER CONVEYOR	2
8	01B05500	STANDARD FOOT PAD WELDMENT	2

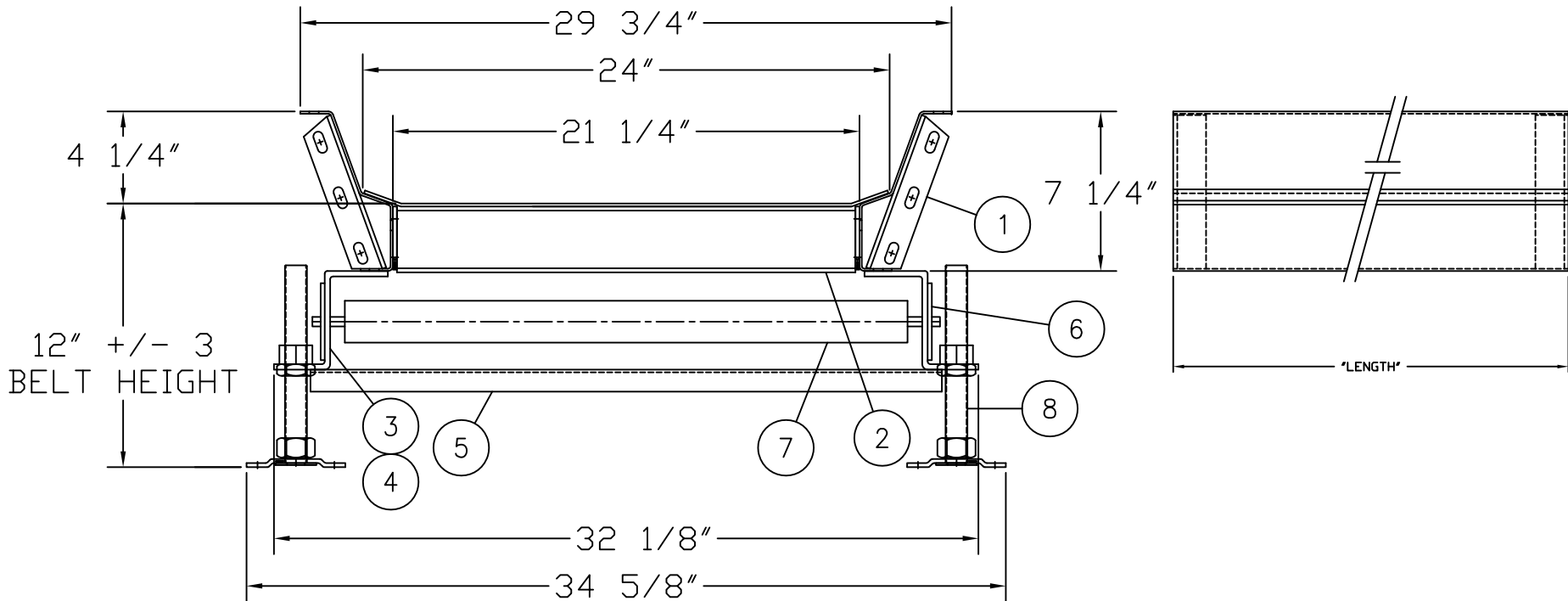

NOTES:
 MINIMUM BELT HEIGHT IS 8"
 ONE SUPPORT PROVIDED EACH SECTION
 TWO RETURN ROLLERS PER 10' SECTION



7620 EVERGREEN ST.
 LIMA, NY 14485
 (v) 585.624.7850 (f) 585.624.8015
 1.888.NECONVEY (1.888.632.6683)
 (e) conveyor@neind.com

PART NO: 00B30321
 CULLET CONVEYOR ROLLER BED ASSEMBLY
 STANDARD SIDES
 24" BELT WIDTH

ITEM	PART NO.		
1	01B30001	ROLLER STYLE SIDE FRAME WELDMENT	2
2	01B30065	ANGLE CROSS TIE WELDMENT	3
3	01B30600	SUPPORT WELDMENT 10"-16" BELT HEIGHT	2
4	02B30300	RETURN ROLLER MOUNTING BRACKET	4
5	02B30685	10"-16" SUPPORT BRACE	2
6	02B30305	KEEPER PLATE RETURN ROLL	4
7	02B30845	RETURN ROLLER SLIDER/ROLLER CONVEYOR	2
8	01B05500	STANDARD FOOT PAD WELDMENT	2
9	05B30815	CARRY ROLLER SLIDER/ROLLER CONVEYOR	5

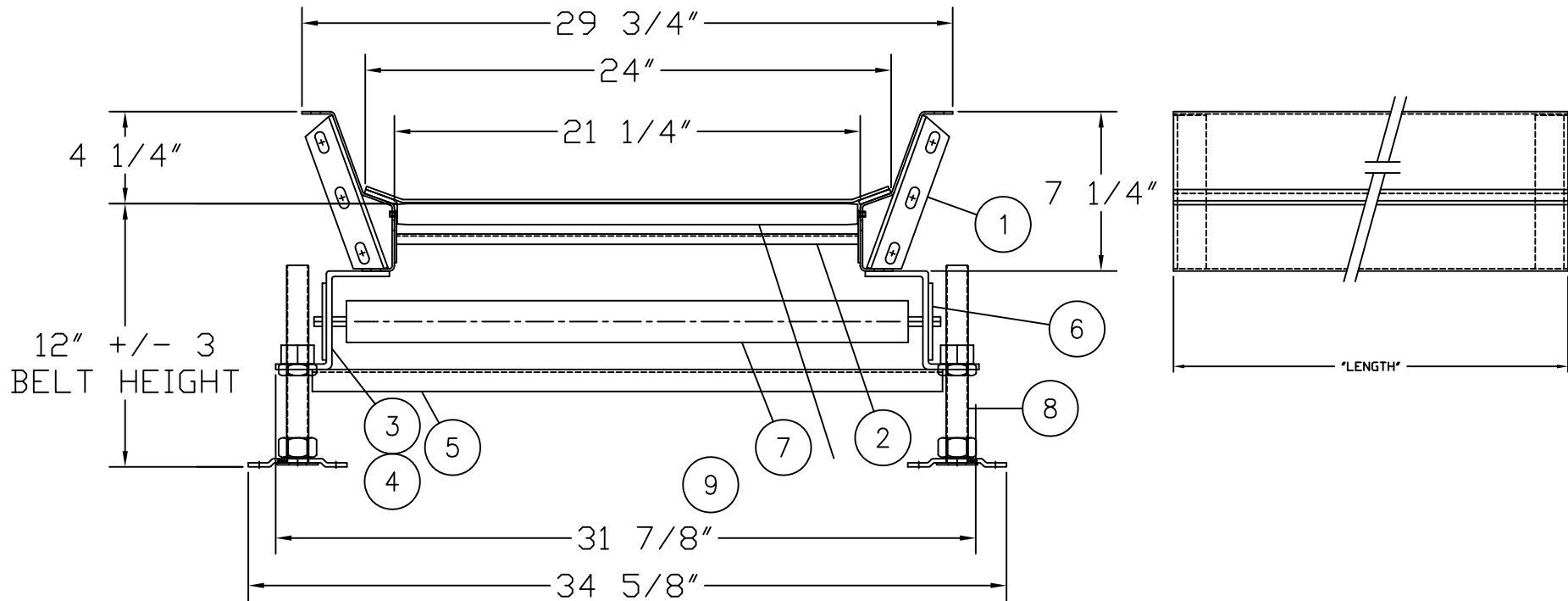

NOTES:
 MINIMUM BELT HEIGHT IS 8"
 ONE SUPPORT PROVIDED EACH SECTION
 TWO RETURN ROLLERS PER 10' SECTION



7620 EVERGREEN ST.
 LIMA, NY 14485
 (v) 585.624.7850 (f) 585.624.8015
 1.888.NECONVEY (1.888.632.6683)
 (e) conveyor@neind.com

PART NO: 00B30322
 CULLET CONVEYOR SLIDER BED ASSEMBLY
 HIGH SIDES
 24" BELT WIDTH

ITEM	PART NO.		
1	01B30004	SLIDER STYLE SIDE FRAME WELDMENT	2
2	01B30115	CHANNEL CROSS TIE WELDMENT	3
3	01B30600	SUPPORT WELDMENT 10"-16" BELT HEIGHT	2
4	02B30300	RETURN ROLLER MOUNTING BRACKET	4
5	02B30685	10"-16" SUPPORT BRACE	2
6	02B30305	KEEPER PLATE RETURN ROLL	4
7	02B30845	RETURN ROLLER SLIDER/ROLLER CONVEYOR	2
8	01B05500	STANDARD FOOT PAD WELDMENT	2

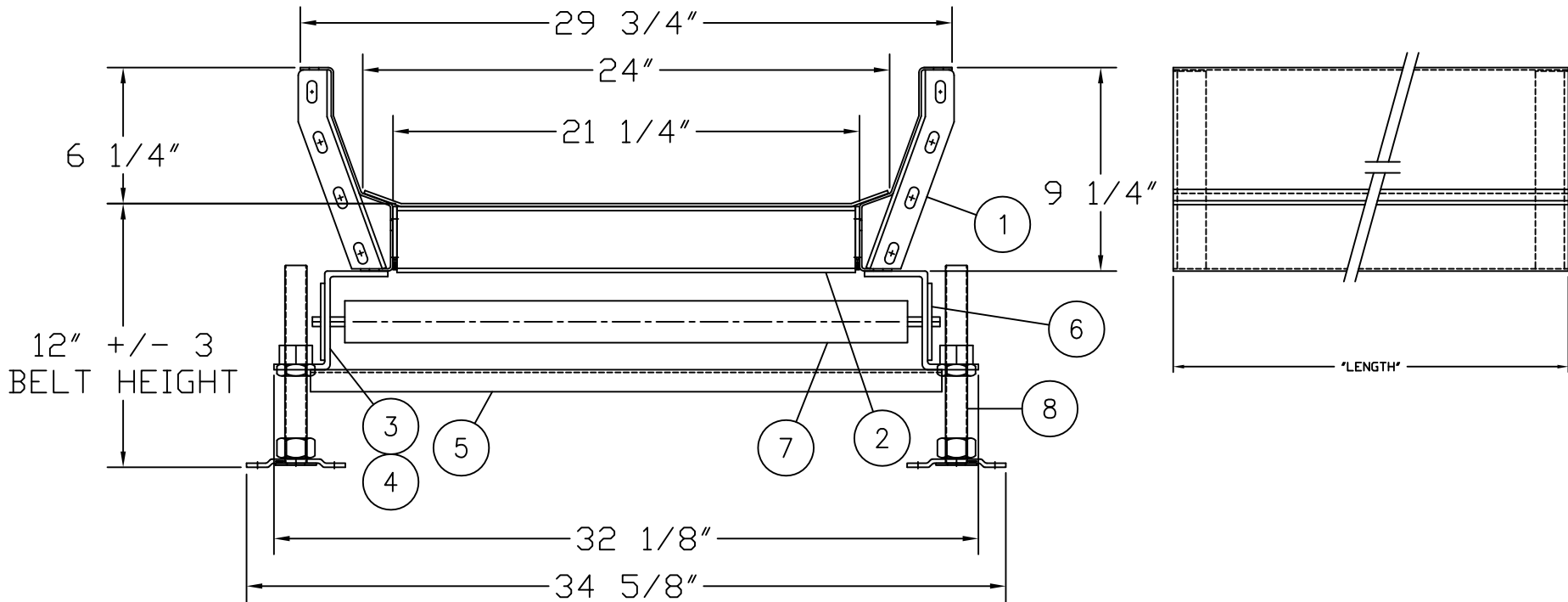

NOTES:
 MINIMUM BELT HEIGHT IS 8"
 ONE SUPPORT PROVIDED EACH SECTION
 TWO RETURN ROLLERS PER 10' SECTION



7620 EVERGREEN ST.
 LIMA, NY 14485
 (v) 585.624.7850 (f) 585.624.8015
 1.888.NECONVEY (1.888.632.6683)
 (e) conveyor@neind.com

PART NO: 00B30323
 CULLET CONVEYOR ROLLER BED ASSEMBLY
 HIGH SIDES
 24" BELT WIDTH

ITEM	PART NO.		
1	01B30006	ROLLER STYLE SIDE FRAME WELDMENT	2
2	01B30065	ANGLE CROSS TIE WELDMENT	3
3	01B30600	SUPPORT WELDMENT 10"-16" BELT HEIGHT	2
4	02B30300	RETURN ROLLER MOUNTING BRACKET	4
5	02B30685	10"-16" SUPPORT BRACE	2
6	02B30305	KEEPER PLATE RETURN ROLL	4
7	02B30845	RETURN ROLLER SLIDER/ROLLER CONVEYOR	2
8	01B05500	STANDARD FOOT PAD WELDMENT	2
9	05B30815	CARRY ROLLER SLIDER/ROLLER CONVEYOR	5

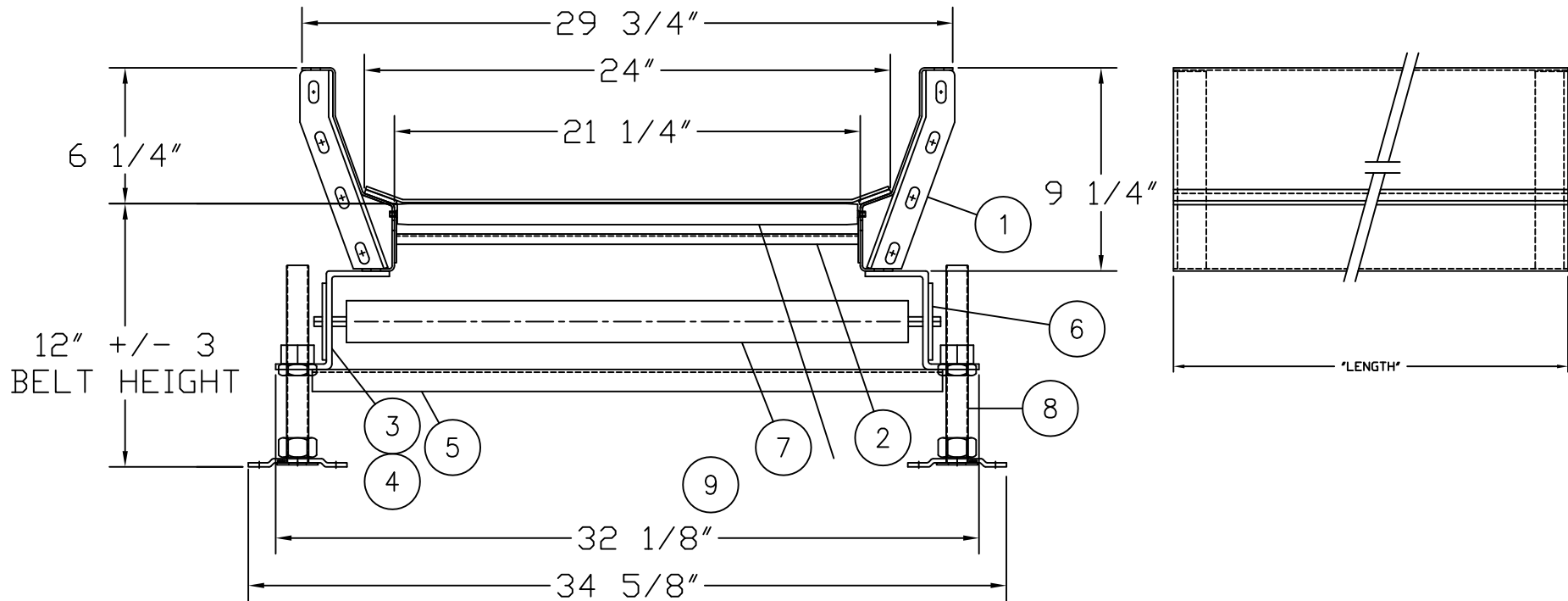

NOTES:

MINIMUM BELT HEIGHT IS 8"
 ONE SUPPORT PROVIDED EACH SECTION
 TWO RETURN ROLLERS PER 10' SECTION



C:/ACAD/PROD/30/00B30323

7620 EVERGREEN ST.
 LIMA, NY 14485
 (v) 585.624.7850 (f) 585.624.8015
 1.888.NECONVEY (1.888.632.6683)
 (e) conveyor@neind.com